

MAIN OFFICE

7616 Lee Highway
Chattanooga, TN 37421
Phone: 423-892-8620
Fax: 423-892-2107
Toll Free: 800-262-6669

RPI

ROOF PRODUCTS, INC.

Email: rpcurbs@comcast.net
Visit us on the web at www.rpcurbs.com

WEST COAST

203 South 57th Drive
Phoenix, AZ 85043
Phone: 602-442-8353
Fax: 602-442-8494
Toll Free: 866-500-8353

TYPICAL INSTALLATION INSTRUCTIONS

RPC-3 non-canted and RPC-2 canted insulated structural Roof Curbs

Model RPC-3 is designed to be installed directly to the structural supports of your roof. However, it can also be installed on top of the metal roof deck. It is recommended for either modified bitumen built up or single ply membrane roofs. This makes it the most widely used type of pre-fabricated roof curb for conventional (non-pre engineered metal building) roof applications.

Model RPC-2 is designed for installation on wood decks.

Typical installation examples, calculations and roof curb details:

1. Attachment details when roof curb is directly attached to the structure. (fig. 1, 2, 3 & 4)
2. RPC-3 Roof Curb is installed directly to angle framing or bar joist (fig. 5 & 5A)
3. RPC-3 Roof Curb is installed on top of metal roof decking (fig. 6 & 6A)
4. RPC-2 installed on wood decking. (fig. 7)
5. Model RPC-3 typical construction details. (fig. 8)
6. Cantilevered roof curb calculations. (fig. 9)
7. Wind force calculations. (fig. 10)

NOTE: When installing roof curbs in between bar joists on top of metal decking weight loads must be considered. Deck may require support framing (option supplied by Roof Products, Inc.). (fig. 11)

NOTE: In the event of local code requirements, seismic applications, and special loading conditions such as horizontal thrust produced by skylights, etc., please call Roof Products, Inc. for additional recommendations.

Sample Installation for RPMB-1 Metal Building Roof Curb.

Model RPMB-1 is the most versatile metal building roof curb. Model RPMB-1 is a one-piece style supplied with loose rib caps. It can be installed over/over, under/over, and under/under the metal building roof panel.

1. Over/Over installation sample. (fig. 12)

Roof Products, Inc. offers several styles of roof curbs for pre-engineered metal buildings. Please call with your requirements for the proper roof curb style and installation instructions.

ROOF CURB TYPICAL ATTACHMENT DETAILS

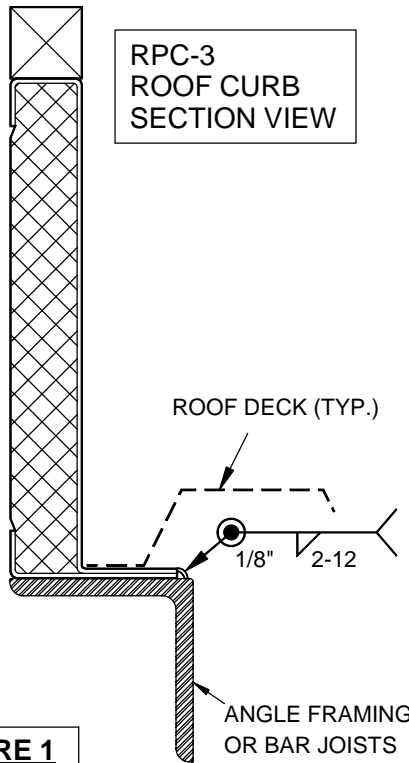

FIGURE 1

**CURB WELDED TO ANGLE FRAMING
OR BAR JOISTS**

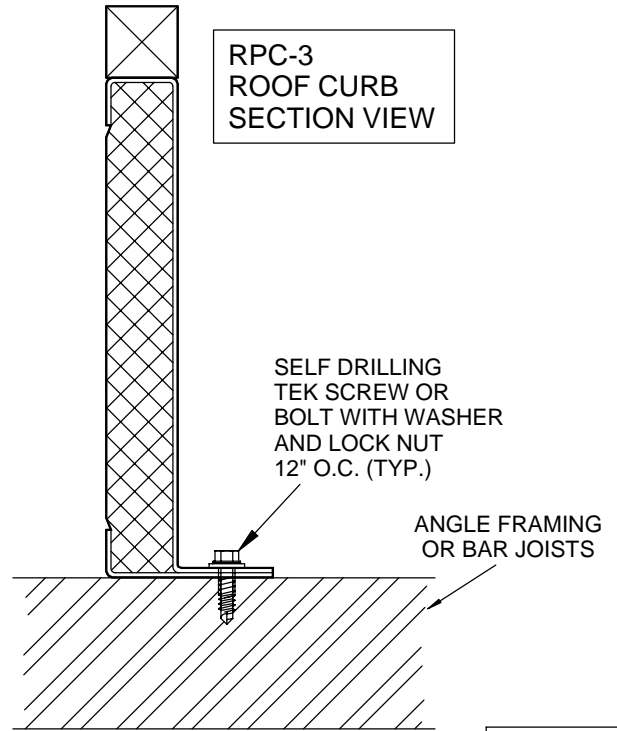

FIGURE 2

**CURB MECHANICALLY FASTENED TO
ANGLE FRAMING OR BAR JOISTS**

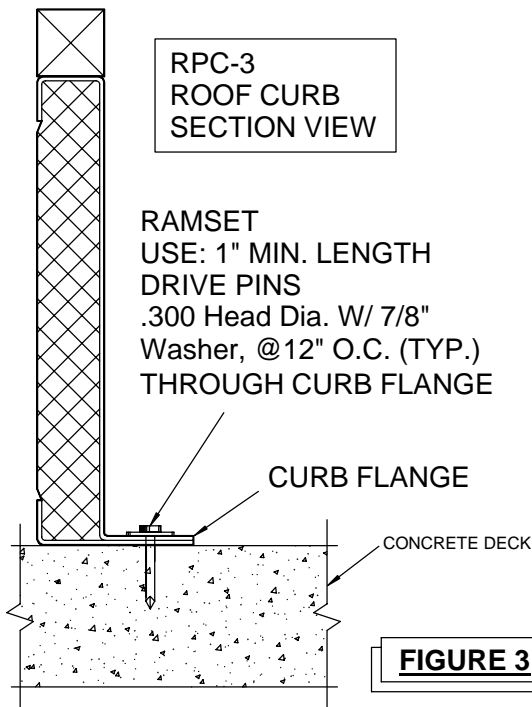

FIGURE 3

**CURB MECHANICALLY FASTENED
TO CONCRETE DECK**

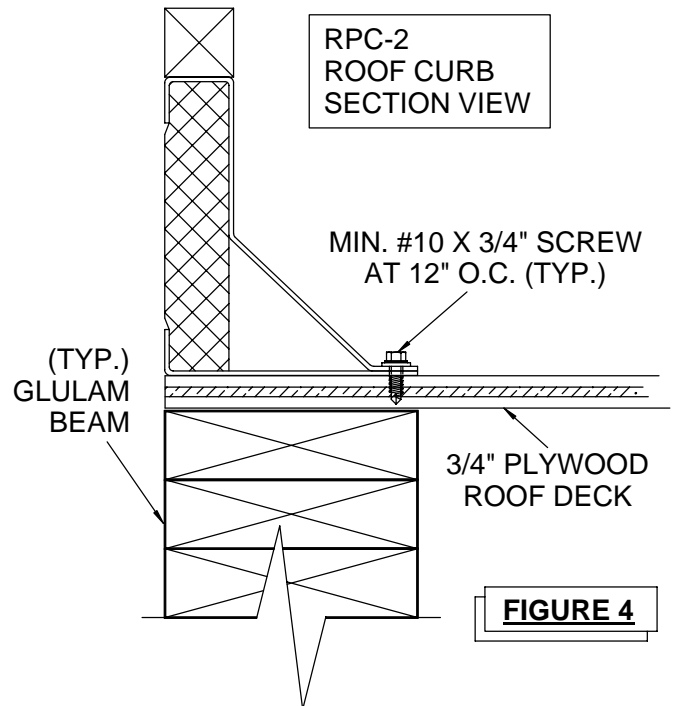
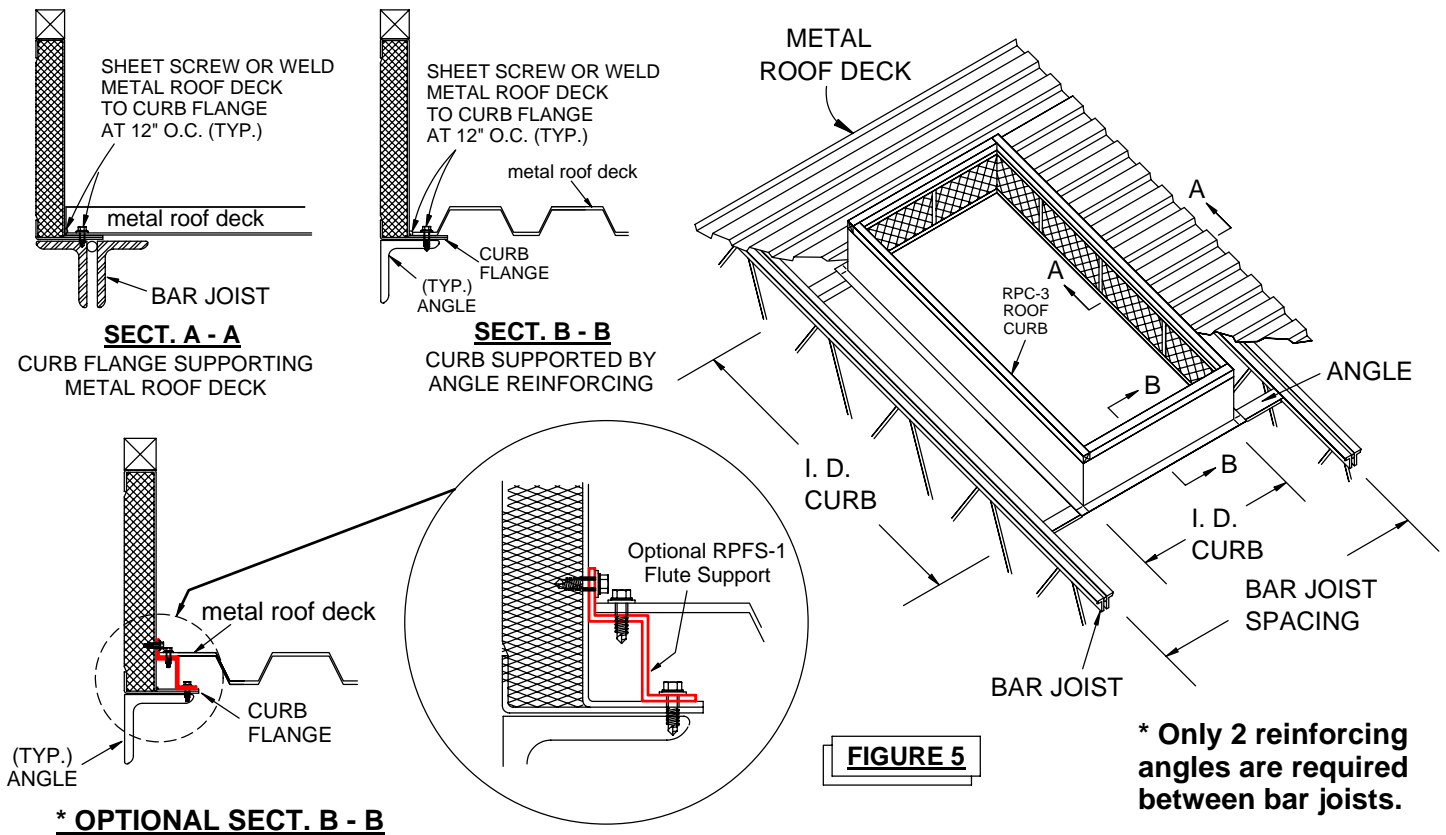

FIGURE 4

CURB INSTALLED ON WOOD DECK

ROOF PRODUCTS, INC. 1-800-262-6669

STRUCTURAL ROOF CURB INSTALLATION ON ANGLES BETWEEN BAR JOISTS



STRUCTURAL ROOF CURB INSTALLATION WHEN SPANNING BAR JOISTS

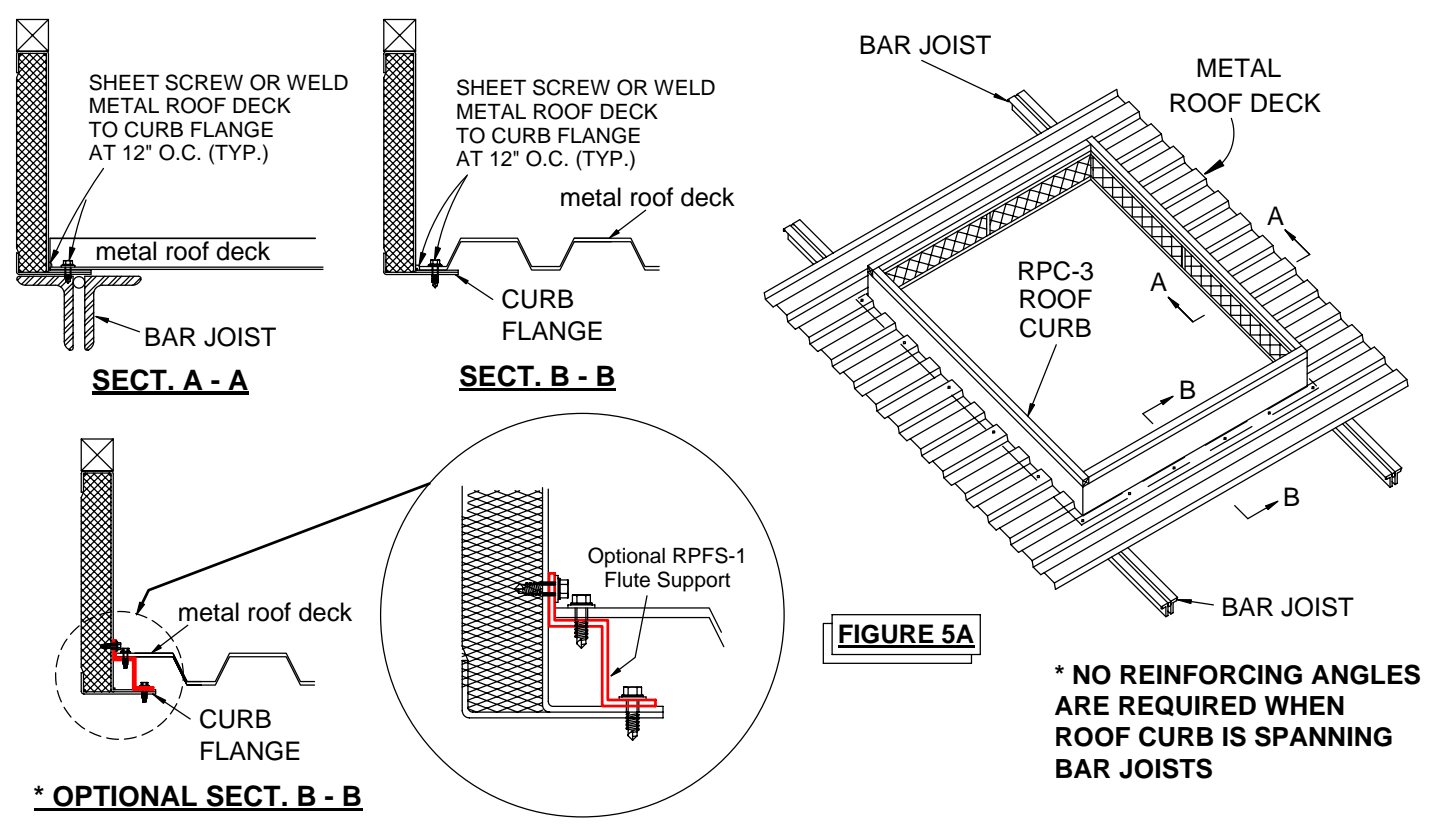

ROOF PRODUCTS, INC. 1-800-262-6669

STRUCTURAL ROOF CURB INSTALLATION ON TOP OF METAL DECK WITH ANGLES BETWEEN BAR JOISTS

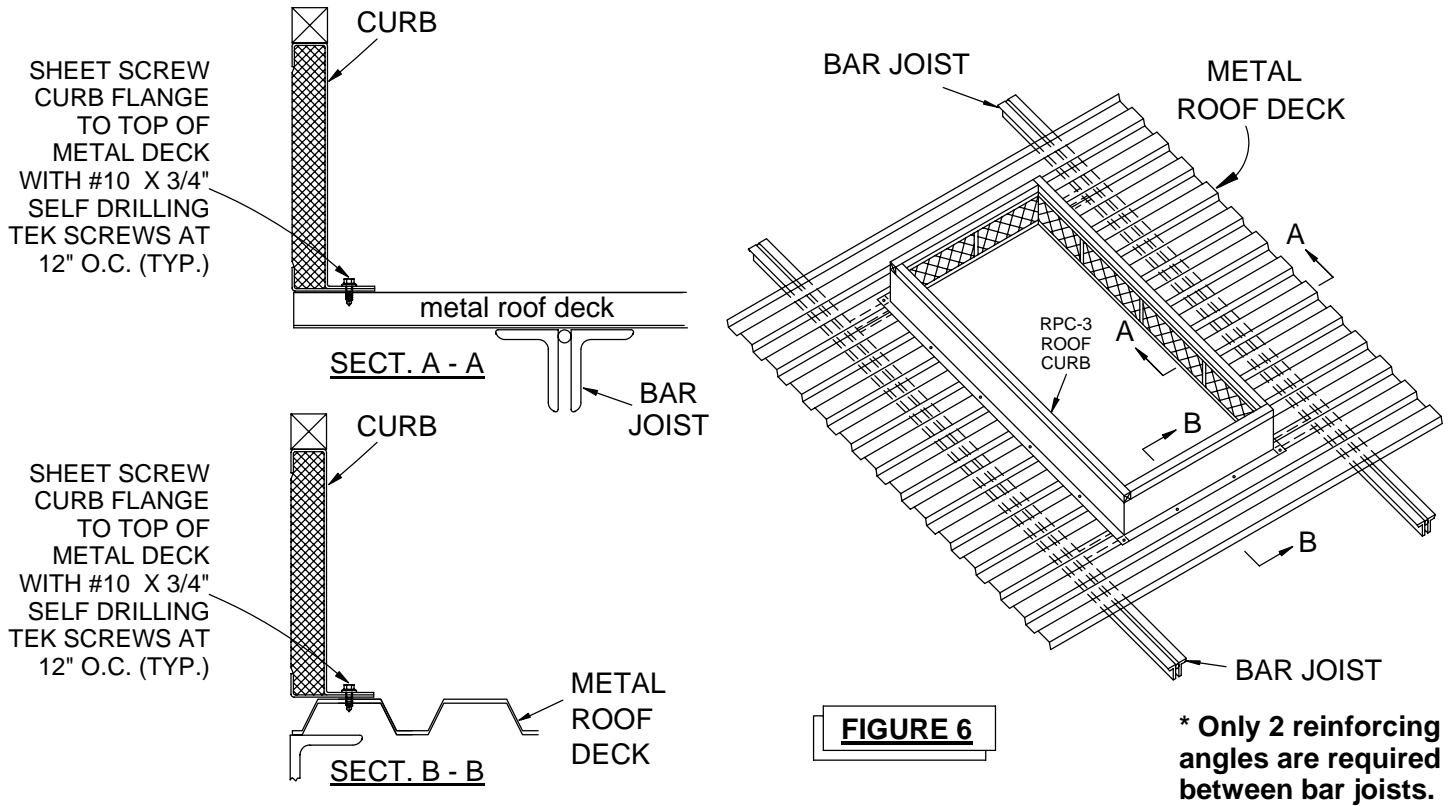

STRUCTURAL ROOF CURB INSTALLATION ON TOP OF METAL DECK WHEN SPANNING BAR JOISTS

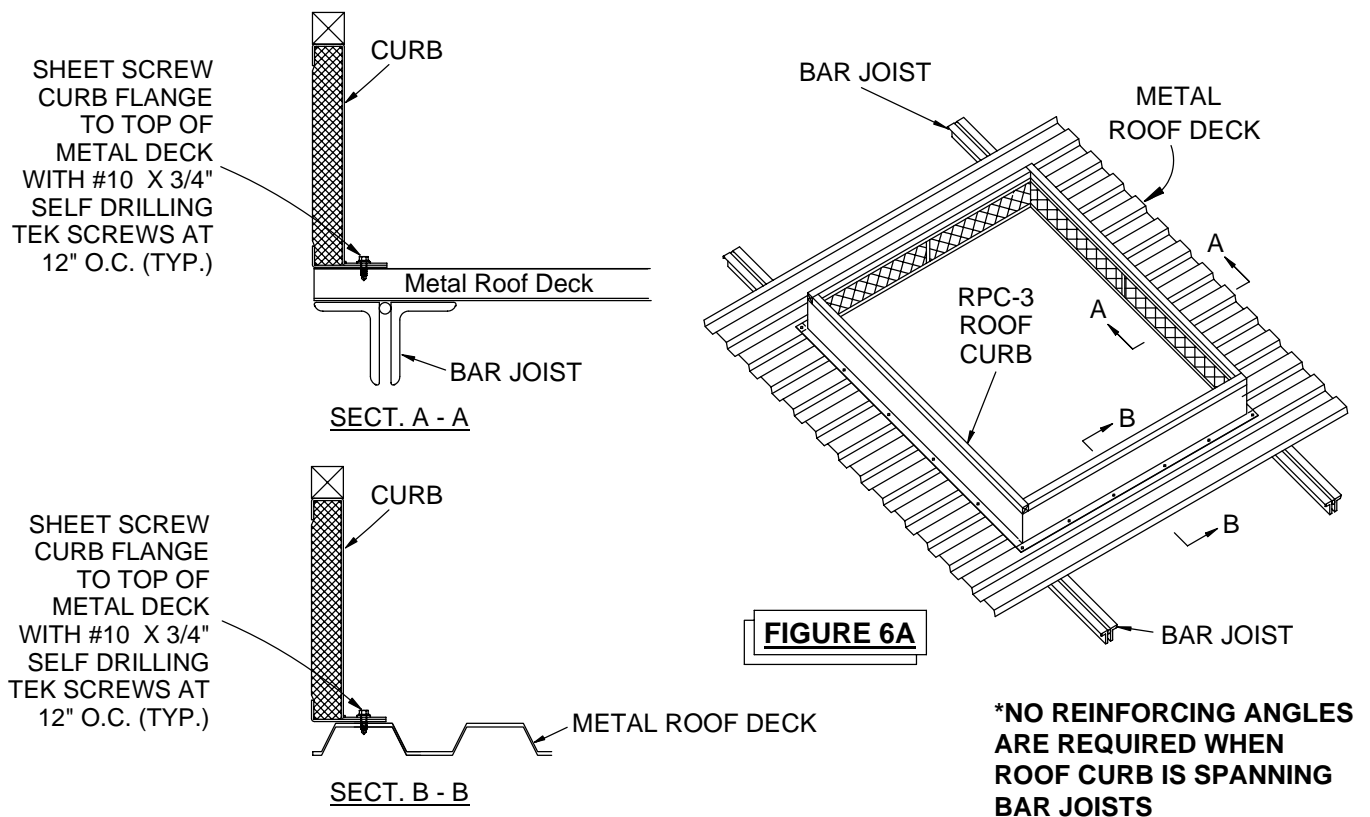

ROOF PRODUCTS, INC. 1-800-262-6669

INSTALLATION INSTRUCTIONS FOR RPC-2 STRUCTURAL ROOF CURB

Model RPC-2 is designed to be installed directly on top of plywood Roof Deck.

To install an RPC-2 directly onto the roof structure, you must:

1. Locate curb per plans.
2. Curb mechanically fastened to plywood roof deck at 12" o.c.

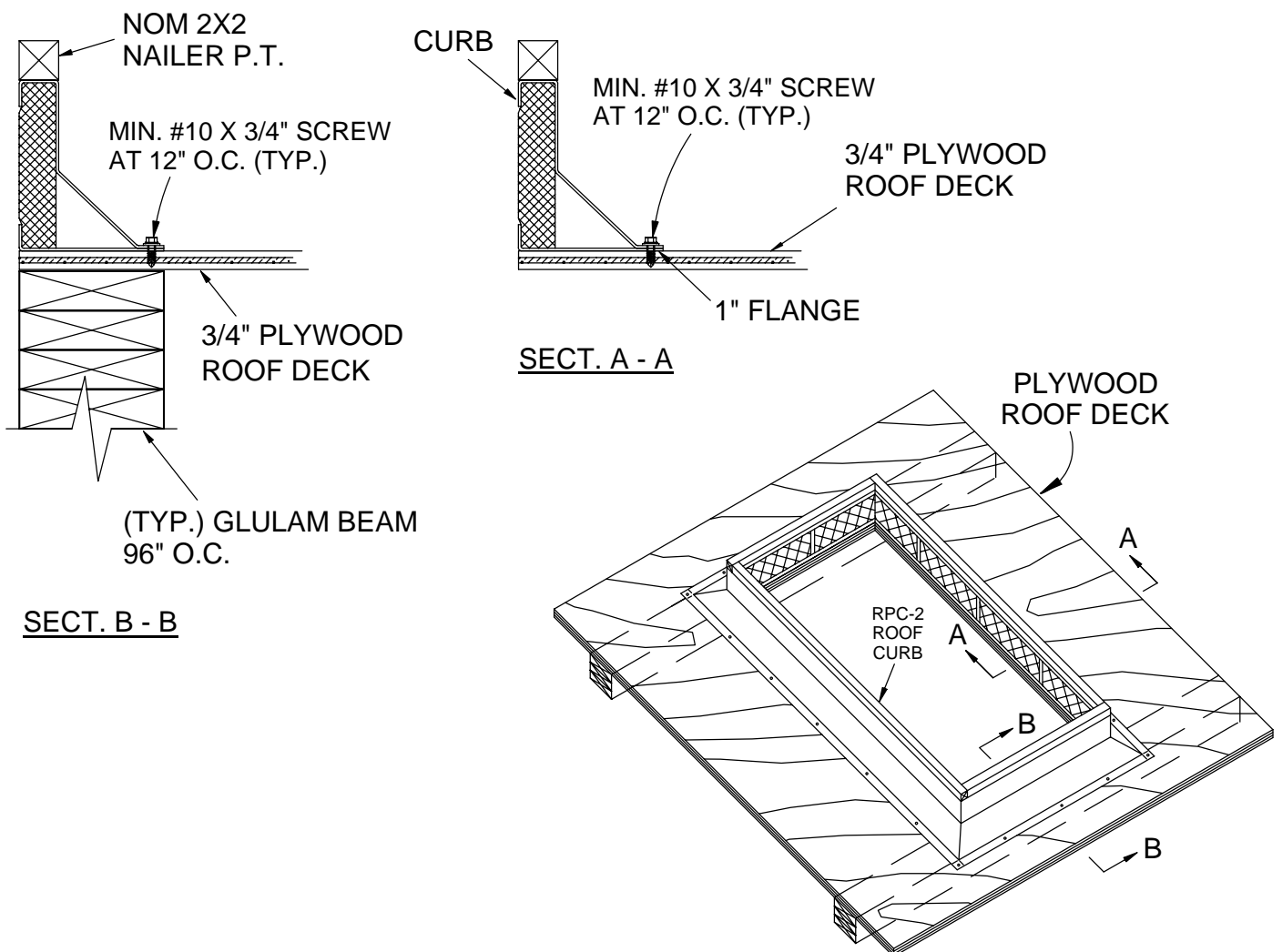

FIGURE 7

ROOF PRODUCTS, INC. 1-800-262-6669

CANTILEVER ROOF CURB CALCULATIONS OVER MINIMUM OF TWO BAR JOISTS

ROOF CURB DIMENSIONS: 80" X 156" WEIGHT: 2650#

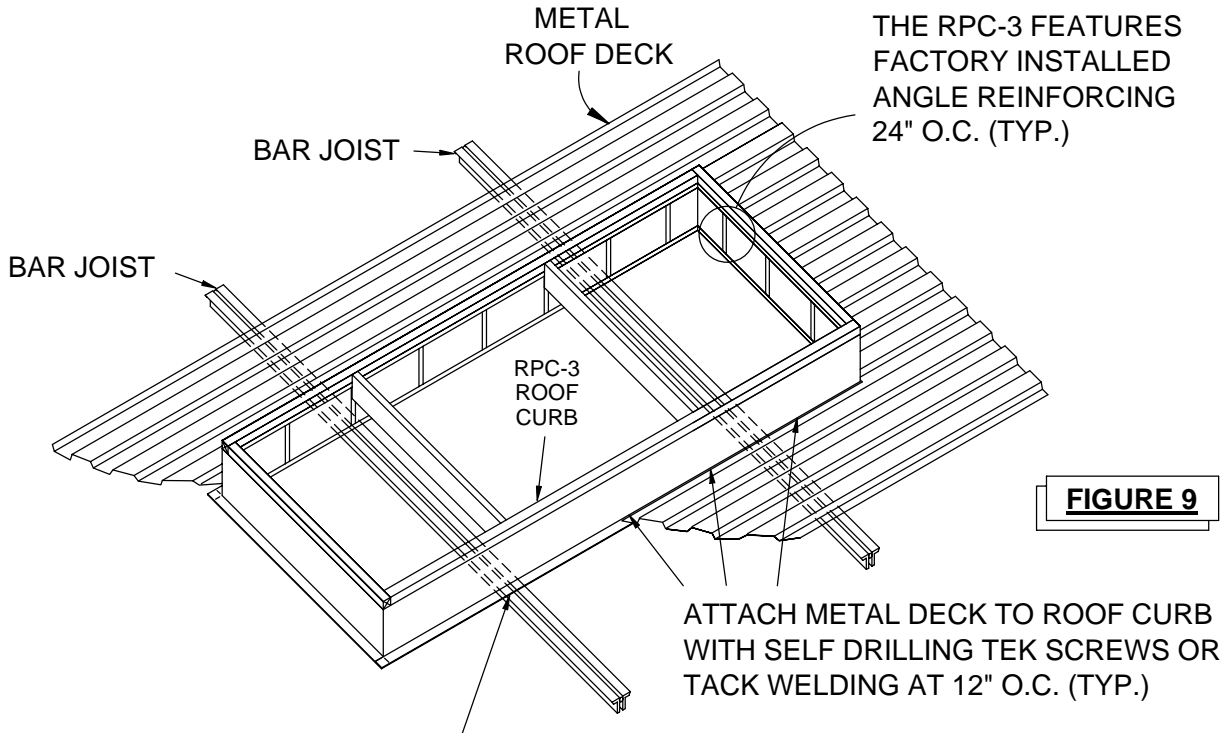
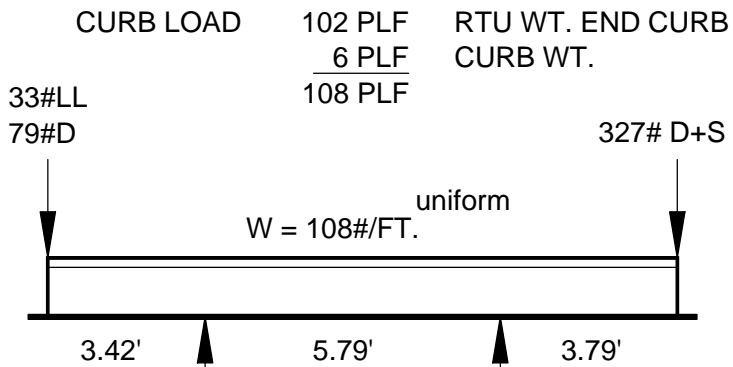

FIGURE 9

PUDDLE WELD CURB TO BAR JOISTS
METAL DECK TO BE INSTALLED OVER CURB FLANGE

$$\frac{40.5'}{7} = 5' 9\text{-}1/2''$$



$$\begin{aligned} 1(10) &= 10 \\ 1(28) &= 28 \\ &38 \text{ PLF} \end{aligned}$$

$$R = \frac{38(6.67)}{2} = 126.7\#$$

$$P_C = 200\#$$

$$P_{TOT} = 327\#$$

$$\begin{aligned} V &= 777\# \\ M &= 1863\# \end{aligned}$$

$$\begin{aligned} V &= 736\# \\ M &= 2015\# \end{aligned}$$

$$\begin{aligned} M_A &= 8258\# \\ V_A &= 2753\# \end{aligned}$$

$$\left(\frac{2015}{8258}\right)^2 + \left(\frac{736}{2753}\right)^2 = .06 + .07 = .13 < 1.0 \text{ OK}$$

$$\text{OR } \left(\frac{2015}{9508}\right)^2 + \left(\frac{736}{2753}\right)^2 = .04 + .07 = .11 < 1.0 \text{ OK}$$

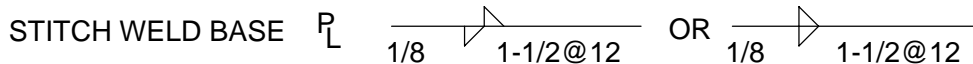

BENNETT & PLESS
INCORPORATED

DATE 2-20-92

WIND FORCE CALCULATIONS

WIND FORCE 20 #/ϕ'

UPLIFT FORCE (.7)(20) = 14#/ϕ'

AREA = 4' X 8' = 32 SQ. FT.

UPLIFT LOAD TOTAL = (32SQ.FT.)(14#/SQ. FT.) = 448#

① WT OF UNIT 150#

TOTAL
UPLIFT = 298#

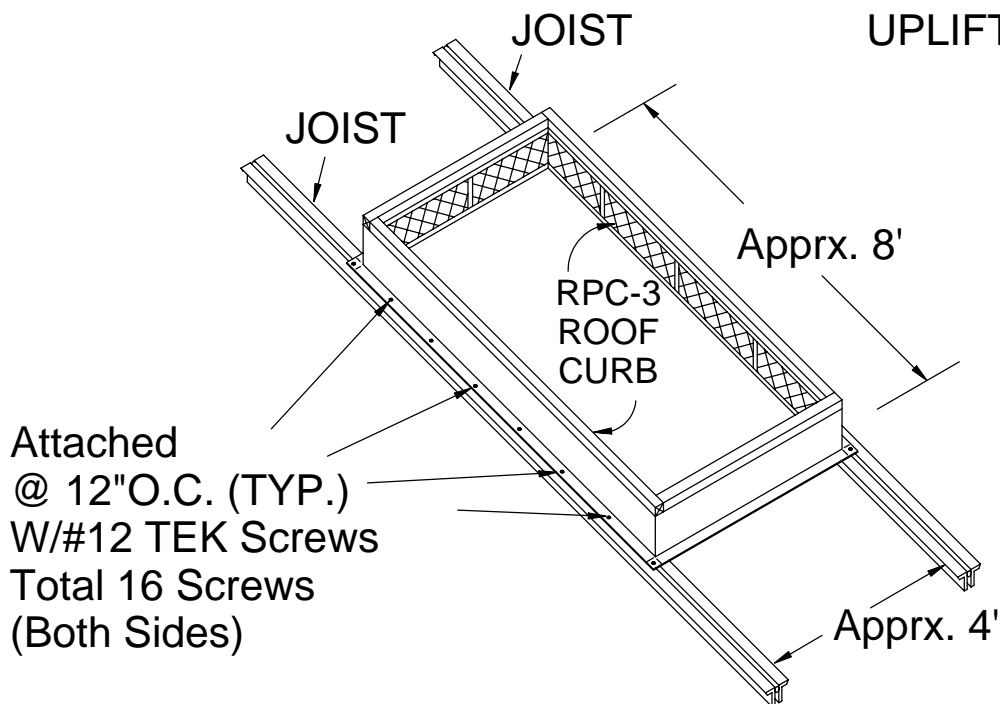

FIGURE 10

UPLIFT FORCE AT ATTACHMENT

$$P = \frac{298}{16} = 18.6\#$$

ATTACHED W/ #12 TEK SCREWS

ALLOWABLE TENSION LOAD / SCREW = 325# > 18.6#

◦ ◦ UNIT OK FOR UPLIFT

② SAME LOAD / SCREW FOR 5' X 6' UNIT

◦ ◦ UNIT OK FOR UPLIFT

STRUCTURAL ROOF CURB INSTALLED ON TOP OF EXISTING OR NEW METAL DECK WITH SUPPORT FRAMING

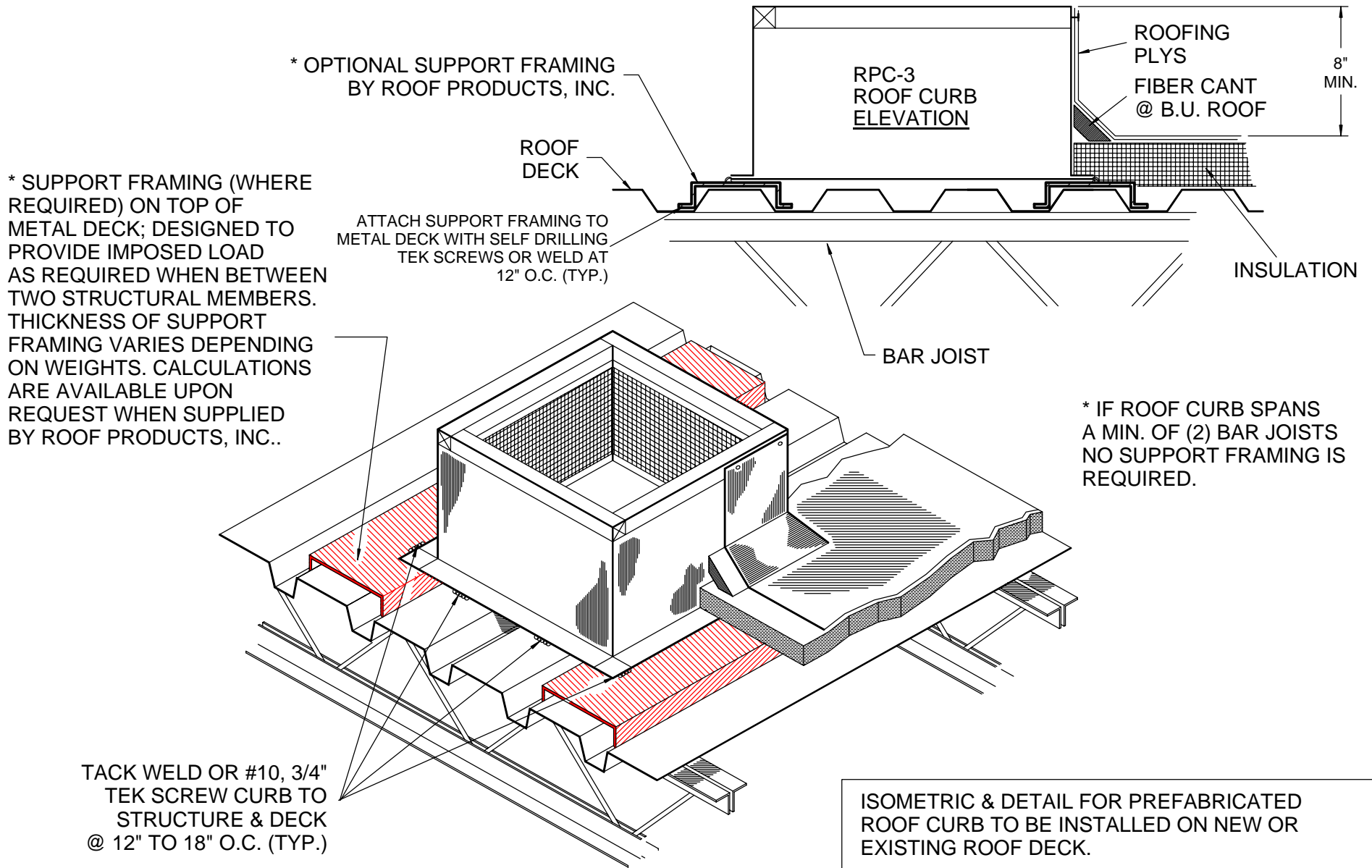
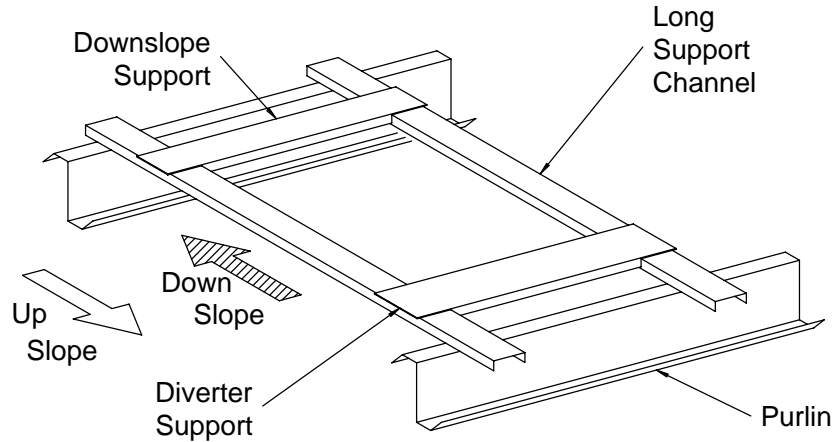

FIGURE 11

RPMB-1 (ONE PIECE, WITH LOOSE RIBS) METAL BLDG. ROOF CURB INSTALLATION FOR OVER-OVER R & SSR ROOF PANELS ON NEW CONSTRUCTION

(1) Place and position long supports 6" beyond purlins. Attach downslope and diverter support to long support. Minimum of 2 parallel supports required. (Do not attach long supports to structure.)

(2) Attach Roof Panels



(3) Make roof cut-out to curb outside dimensions plus 6" on ridge side, and 1 1/2" on eave side.

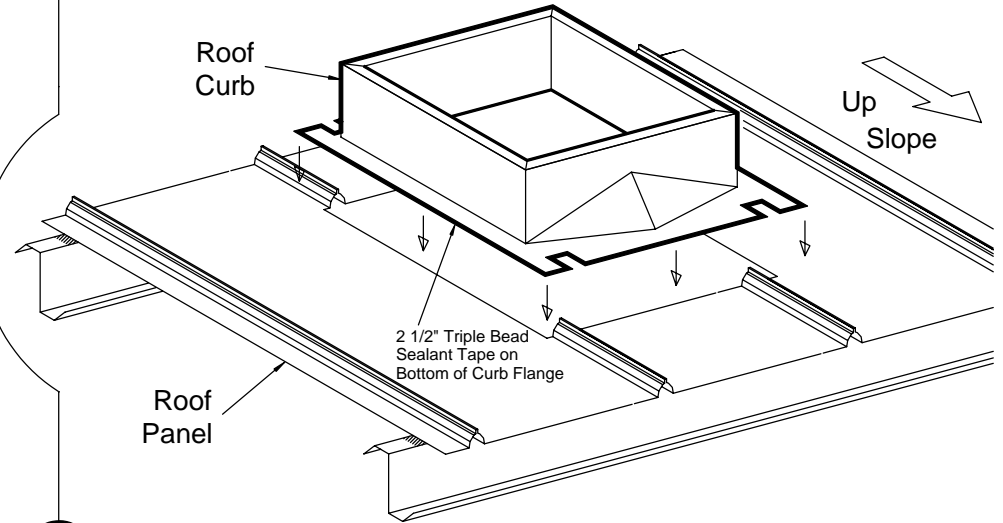

(7) Attach loose panel ribs with compatible fasteners. Apply even bead of Tube Caulk to full perimeter of Roof Curb and Loose Panel Ribs.

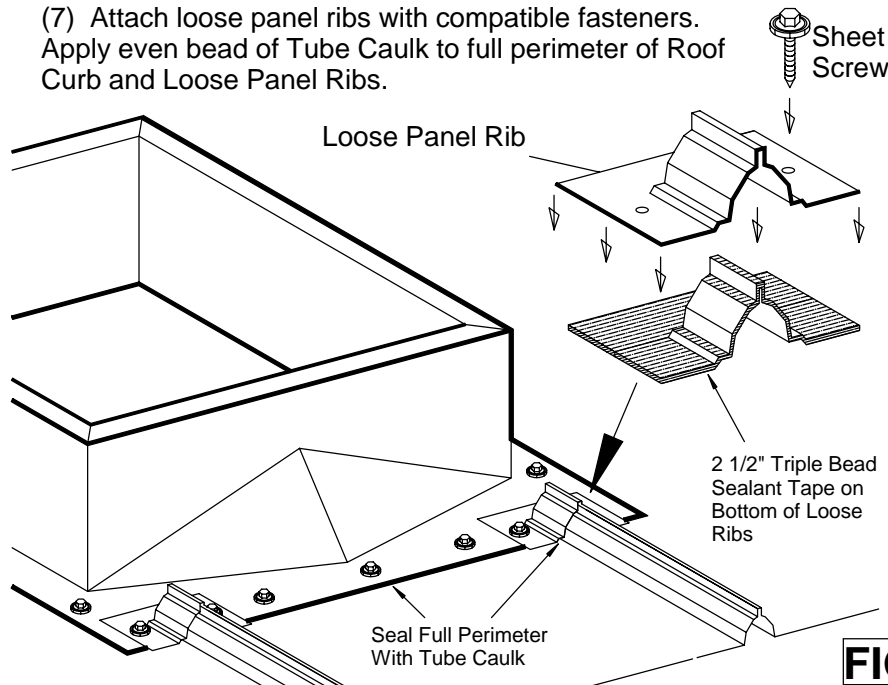

(4) Notch roof curb to allow curb to sit in the flat of panel.

(5) Turn Roof curb upside down then apply 2 1/2" Triple Bead Sealant Tape to full perimeter of Roof Curb Flange.

(6) Attach curb to roof panel with screws spaced no more than 4" o.c.

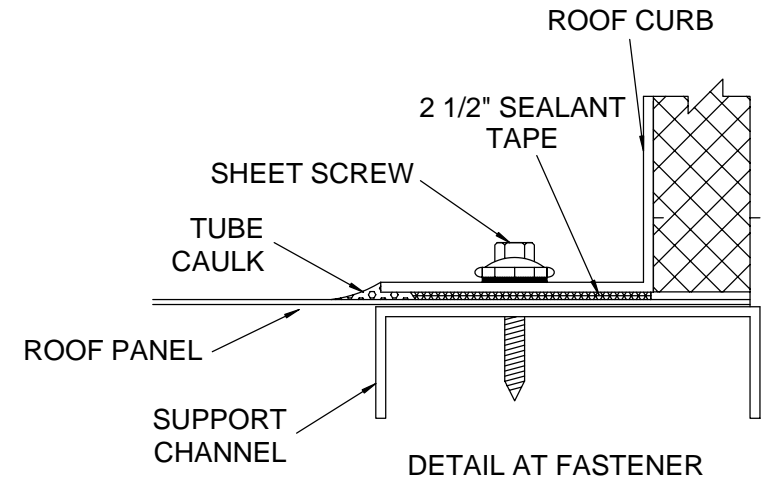

FIGURE 12